

A

B

C

D

E

F

REV	ECN No.	DESCRIPTION	DESIGN	DATE
A0		NEW RELEASE	蒋建银	2019.01.17

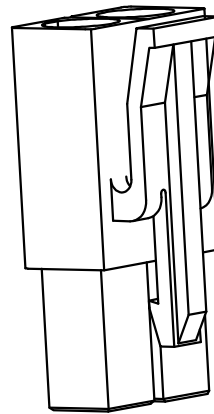
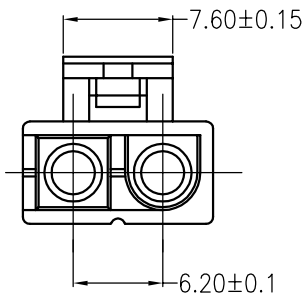
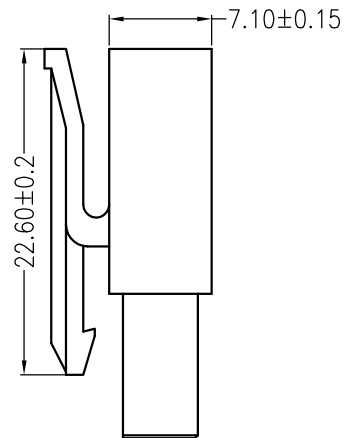
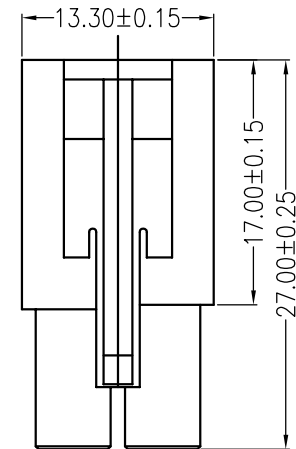
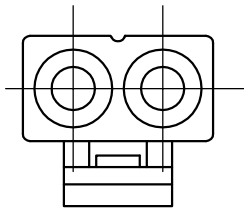

### 主要技术参数 Main Specifications

线数 (Poles): 02

额定电阻 (Contact resistance):  $\leq 10m\Omega$

绝缘电阻 (Insulation resistance):  $\geq 1000M\Omega$

额定电压 (Rated voltage): 300 V AC DC

额定电流 (Rated current): 15A AC DC

耐电压 (Withstand Voltage): 1800V AC/minute

温度范围 (Temperature Range):  $-25^{\circ}C \sim +85^{\circ}C$

### ORDER INFORMATION:

**C6201P-02-A0T-P**

PART No.

No. OF CIRCUITS:

02

PACKAGING:

P=PE

PLASTIC MATERIAL:

A0T=PA66 (Transparent)

C				
B				
A	HOUSING	1 PCS	PA66	COLOR:(Transparent)
ITEM	COMPONENT	Q'TY	MATERIAL	FINISH

 **东莞市高迪电子有限公司**  
DONG GUAN GAO DI ELECTRONICS CO., LTD

TITLE: C6201P  
6.2mm PITCH HOUSING

X.±0.5	X.±5'	USE: CUSTOMER	PART NO.:
.X±0.3	.X±2'		
.XX±0.25	.XX±1'	APPD: 邵敬和	DWG NO.:
--	--	CHKD: 田峰	
 	UNITS: mm	DR: 蒋建银	SCALE 1 : 1
			SHEET 1 / 1

A

B

C

D

E

F

1

2

3

4

5

1

2

3

4

5

REV	ECN No.	DESCRIPTION	DESIGN	DATE
A0		Release	蒋建银	2019.01.17

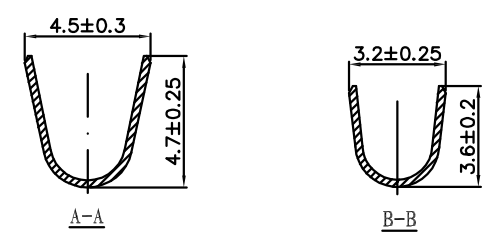
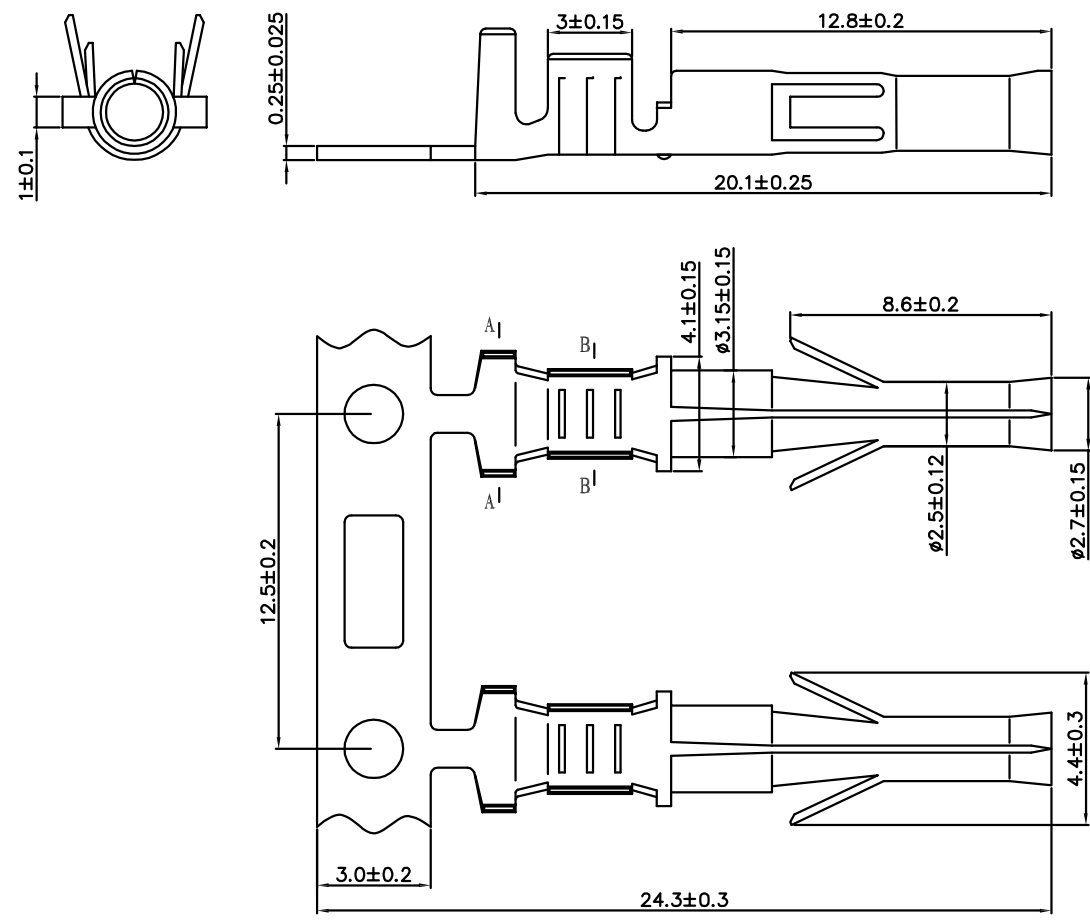

Ordering Information & Specification:

Part No	Wire Range	Insulation O.D.	Material	Finish	Qty/Reel
C6201PT-PA	AWG #22~#16	1.7~3.4mm	Phosphor bronze	Sn-plated	

<b>東莞市高迪電子有限公司</b> DONG GUAN GAO DI ELECTRONICS CO., LTD			TITLE: -	
X.±0.5	X.±5'	USE: CUSTOMER	PART NO.:	
.X±0.3	.X±2'		C6201PT-PA	
.XX±0.25	.XX±1'	APPD: 邵敬和	DWG NO.:	
--	--	CHKD: 田峰	GCDZ-0044	
		UNITS: mm	DR: 蒋建银	SCALE 1 : 1
				SHEET 1 / 1

A

B

C

D

E

F

REV	ECN No.	DESCRIPTION	DESIGN	DATE
A0		NEW RELEASE	蒋建银	2019.01.17

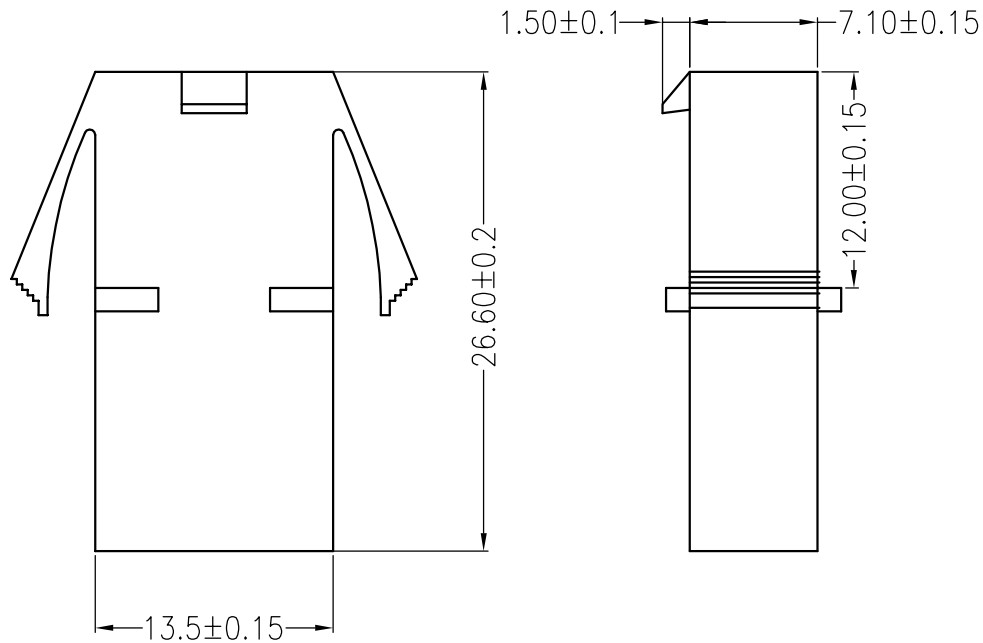

### 主要技术参数 Main Specifications

线数 (Poles): 02

额定电阻 (Contact resistance):  $\leq 10m\Omega$

绝缘电阻 (Insulation resistance):  $\geq 1000M\Omega$

额定电压 (Rated voltage): 300 V AC DC

额定电流 (Rated current): 15A AC DC

耐电压 (Withstand Voltage): 1800V AC/minute

温度范围 (Temperature Range):  $-25^{\circ}C \sim +85^{\circ}C$

### ORDER INFORMATION:

<b>C6201R-02-A0T-P</b>	
PART No. _____	PACKAGING: P=PE
No. OF CIRCUITS: _____	PLASTIC MATERIAL: A0T=PA66 (Transparent)
02	

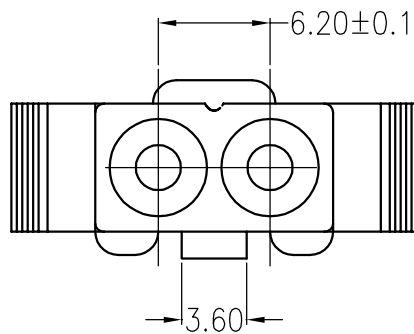

C					
B					
A	HOUSING		1 PCS	PA66	COLOR:(Transparent)
ITEM	COMPONENT	Q'TY	MATERIAL	FINISH	
 <b>东莞市高迪电子有限公司</b> DONG GUAN GAO DI ELECTRONICS CO., LTD			TITLE: C6201R 6.2mm PITCH HOUSING		
X.±0.5	X.±5'	USE:	CUSTOMER		
.X±0.3	.X±2'	APPD:	邵敬和		
.XX±0.25	.XX±1'	CHKD:	田峰		
--	--	DR:	蒋建银		
	UNITS: mm	SCALE	SHEET		
		1 : 1	1 / 1		

A

B

C

D

E

F

1

2

3

4

5

1

2

3

4

5

REV	ECN No.	DESCRIPTION	DESIGN	DATE
A0		Release	蒋建银	2019.01.17

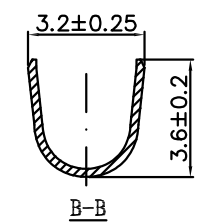
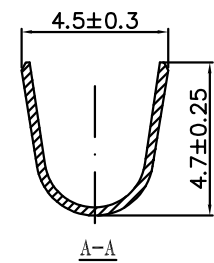
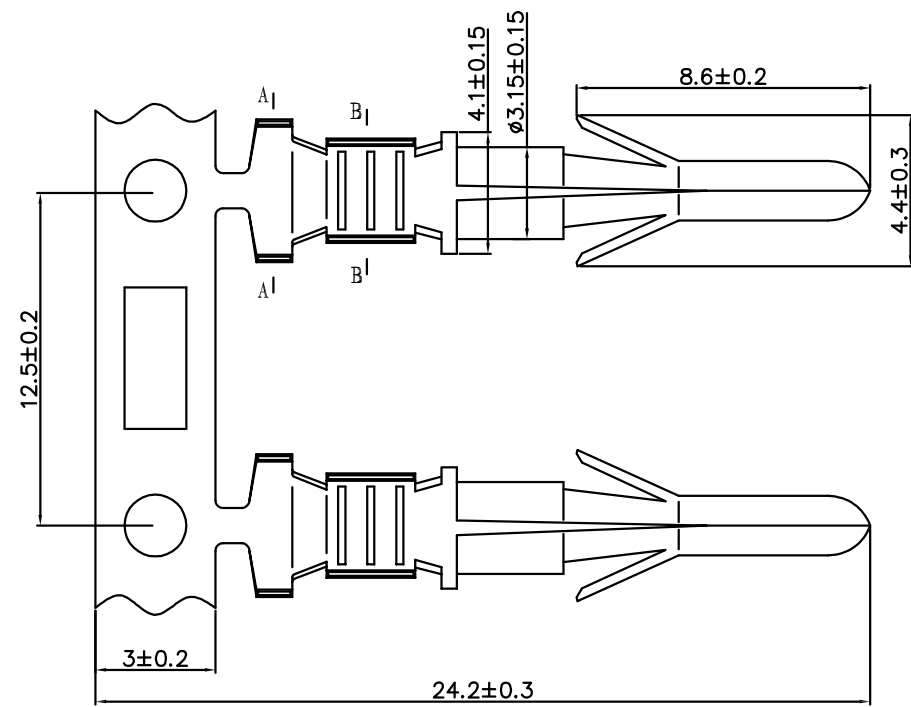
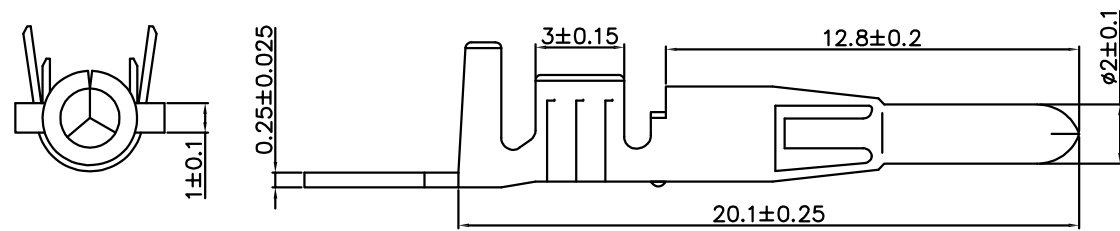

Ordering Information & Specification:

Part No	Wire Range	Insulation O.D.	Material	Finish	Qty/Reel
C6201RT-PA	AWG #22~#16	1.7~3.4mm	Phosphor bronze	Sn-plated	

<b>東莞市高迪電子有限公司</b> DONG GUAN GAO DI ELECTRONICS CO., LTD			TITLE: -	
X.±0.5	X.±5'	USE: CUSTOMER	PART NO.:	
.X±0.3	.X±2'		C6201RT-PA	
.XX±0.25	.XX±1'	APPD: 邵敬和	DWG NO.:	
--	--	CHKD: 田峰	GCDZ-0043	
⊕	◁	UNITS: mm	DR: 蒋建银	SCALE 1 : 1
				SHEET 1 / 1